

heatilator[®]
The first name in fireplaces



Eclipse Series
direct vent gas fireplaces

Eclipse Series

direct vent gas fireplaces



Eclipse 36 with Simon front, ceramic stones, slate surround and Kenwood mantel

Modern Versatility

The Eclipse brings functional modern design into smaller spaces. Its unique size and finishing options provide unmatched versatility. A ribbon burner elevates the flames through finely crafted ceramic stones.

Design your space, your way. With the Eclipse, modern versatility pairs well with the proven value and dependability of Heatilator.

Features:

- Available in 32 and 36-inch sizes
- Glass options to create your unique look
- Clean Face and Simon fronts to match your style
- Optional fade-resistant black glass liner
- Up to 23,500 BTUs



Cover and above: Eclipse 32 with Clean Face front and layered interior of white glass beads and ceramic stones

Personalize with Upgrades

Fronts

Showcase the fire within by selecting a front. Simon or Clean Face fronts add sleek style and clean lines to your finished look.



Simon Front in Black



Clean Face Front in Black

Layered Media Option

A combination of glass and ceramic stones can showcase your modern design in a whole new way.



Media Options

Transform the flames with colored glass and glass beads. Flames rise through each option differently for a unique look.



Cobalt Glass



Ebony Glass



Amber Glass



Crystal Glass



White Glass Beads

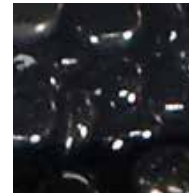

Black Glass Beads

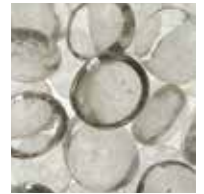

Clear Glass Beads

Black Glass Liner

Multiply the flames and intensify the fire with an optional fade-resistant liner.



Additional Options Not Pictured



- Remote Controls
- Fan Kits
- Mantels and Surrounds

IntelliFire™ Ignition System

The IntelliFire™ Ignition System (IPI) is an advanced intermittent pilot ignition system. IPI constantly monitors ignition, ensures safe functioning and conserves up to \$10/month in energy costs. To learn more about IntelliFire Technology, visit heatilator.com.

Direct Vent Technology

Direct Vent fireplaces remove 100% of combustion exhaust and odors outside of the home. These sealed fireplaces provide optimal heat, conserve energy and ensure clean, safe indoor air quality. To learn more, visit heatilator.com.

Technical Specifications

MODEL	FRONT WIDTH		BACK WIDTH		HEIGHT		DEPTH		VIEWING AREA	BTU/HR INPUT
	UNIT	FRAMING	UNIT	FRAMING	UNIT	FRAMING	UNIT	FRAMING		
ECLIPSE32	36 (914mm)	37" (940mm)	25-3/4 (654mm)	37" (940mm)	34-3/8 [873]	34-3/4" (883mm)	15-7/8 (403mm)	16-1/4" (413mm)	27-3/16" x 18-1/16" (691 x 459mm)	12,000 - 17,500 NG 13,500-17,000 LP
ECLIPSE36	41 (1041mm)	42" (1067mm)	30-3/4 (781mm)	42" (1067mm)	37-7/8 [962]	38-1/4" (972mm)	15-7/8 (403mm)	16-1/4" (413mm)	32-1/16" x 21-1/2" (814 x 546mm)	16,500 - 23,500 NG 16,500-20,500 LP

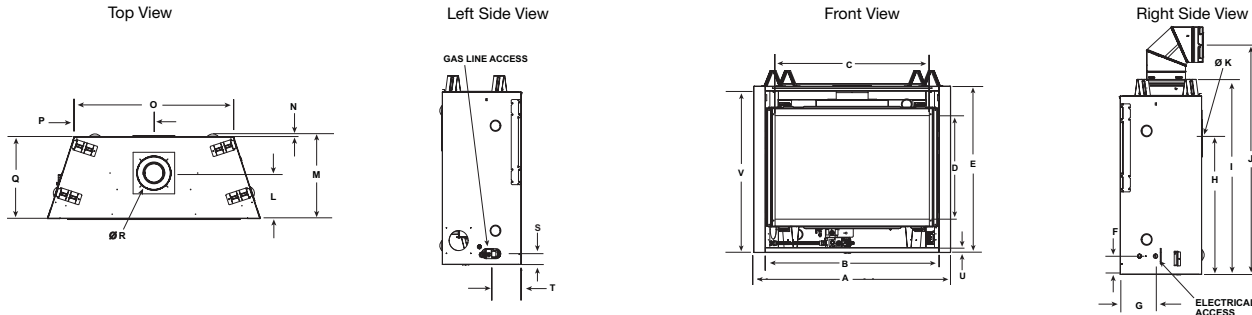

MODEL	A	B	C	D	E	F	G	H	I	J	K	L	M	N	O	P	Q	R	S	T	U	V
ECLIPSE32	36 [914]	31-1/8 [791]	27-3/16 [691]	18-1/16 [459]	31-1/8 [791]	3-9/16 [91]	6-7/8 [175]	23-3/8 [594]	34-3/8 [873]	35-1/2 [902]	8 [203]	8-13/16 [224]	16-5/16 [414]	1/2 [13]	25-3/4 [654]	12-7/8 [327]	15-7/8 [403]	6-5/8 [168]	2-3/16 [56]	6 [152]	1 [25]	30-1/16 [764]
ECLIPSE36	41 [1041]	36-1/8 [918]	32-1/16 [814]	21-1/2 [546]	34-5/8 [880]	3-9/16 [91]	6-7/8 [175]	26-7/8 [683]	37-7/8 [962]	39-15/16 [1014]	8 [203]	8-13/16 [224]	16-5/16 [414]	1/2 [13]	30-3/4 [781]	15-3/8 [391]	15-7/8 [403]	6-5/8 [168]	2-3/16 [56]	6 [152]	1 [25]	33-9/16 [853]

U.S. Efficiencies

Steady State - Since most homeowners use their fireplaces for an extended time while they are in the room, Steady State measures how efficiently your fireplace converts fuel to heat once it is warmed up and running in a "steady state".

AFUE - AFUE rating is more typically used with appliances, like your furnace, that continually cycle on and off to maintain a constant temperature.

Canada Efficiencies

EnerGuide (CSA P.4.1-02) - EnerGuide is a rating used in Canada to measure annual fireplace efficiency.

Rating	Eclipse 32	Eclipse 36
Steady State	68% NG	74% NG
AFUE	48.5% NG	57.1% NG
Rating	Eclipse 32	Eclipse 36
CSA P.4.1-02	51% NG	56% NG

Clearances

MODEL	A	B	C	D	E	F	G
ECLIPSE32	42" [1067mm]	37" [940mm]	59-1/2" [1511mm]	See Install Manual for Alcove Projections	1" [25mm]	1/2" [13mm]	44" [1118mm]
ECLIPSE36	45-1/2" [1168mm]	42" [1067mm]	64-3/8" [1635mm]		1" [25mm]	1/2" [13mm]	45-1/2" [1156mm]
MODEL	H	I	J	K	L	M	N
ECLIPSE32	62-14" [1581mm]	16-1/4" [413mm]	48-1/2" [1232mm]	See Install Manual for Alcove Projections	15-1/16" [383mm]	7-1/2" [191mm]	7-1/8" [181mm]
ECLIPSE36	64-3/8" [1635mm]	16-1/4" [413mm]	48-1/2" [1232mm]		16-5/8" [422mm]	7-1/2" [191mm]	9" [229mm]

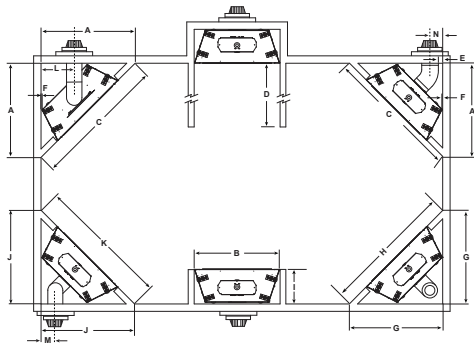

Framing

MODEL	A		B	C		D
MODEL	DVP	SLP		DVP	SLP	
ECLIPSE32	10" [254mm]	8-5/8" [219mm]	34-3/4" [883mm]	16-1/4" [413mm]	16-1/4" [413mm]	37" [940mm]
ECLIPSE36	10" [254mm]	8-5/8" [219mm]	38-1/4" [972mm]	16-1/4" [413mm]	16-1/4" [413mm]	42" [1067mm]
MODEL	E	F	G	H	I	J
ECLIPSE32	32" [813mm]	0" [0mm]	0" [0mm]	1/2" [13mm]	1/2" [13mm]	36" [914mm]
ECLIPSE36	32" [813mm]	0" [0mm]	0" [0mm]	1/2" [13mm]	1/2" [13mm]	36" [914mm]

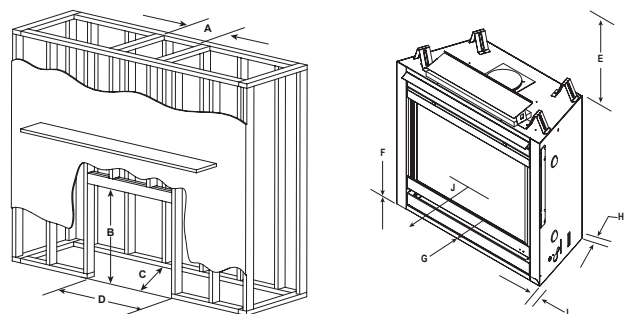

The rough framing dimensions shown represent the distance from stud to stud only and do not take into consideration the addition of drywall. Please refer to installation instructions for complete specifications and drawings when installing this product. Go to heatilator.com to download.

Available From

heatilator
The first name in fireplaces

Limited Lifetime Warranty*

The strongest in the industry, Heatilator provides a limited lifetime warranty on gas-burning products of the most important aspects: firebox and heat exchanger.

*For full warranty details go to heatilator.com.

The information provided in this literature is for planning purposes only and subject to change. Please consult the installation manual for actual installation. Actual product appearance may differ from product images.

Fireplace glass and other surfaces get extremely HOT and can cause severe burns if touched. Do not remove the protective safety screen from the front of the glass. Keep a safe distance away. To learn more visit www.heatilator.com/fireplacesafety.



HTL-1094U-0316

